



Science and Engineering Symposium
4th International Science, Social Science, Engineering and Energy Conference 2012

High Power Step-Up Push-Pull DC-DC Converter with Parallel-Input/Series-Output for 3-phase Inverter Drive Aerator Water Treatment Application

Th. Thongleam^{a,*}, W. Bua-ngam^a, H. Dinsakul^a, B. Jarernpun^a

*^aSchool of Electronics Engineering, Faculty of Science and Technology,
Nakhon Pathom Rajabhat University, Nakhon Pathom, 73000, Thailand*

Abstract

This paper presented the design and implementation of high power step up push-pull converter, which designed for 3-phase inverter drive aerator water treatment application. The proposed converter circuit is designed based on push-pull dc-dc converter, which controlled output voltage by IC SG3525 circuit, the switching frequency equal to 50 kHz. The proposed converter circuit used transformer is 4 units, which is implemented by 4 primary parallels and 4 secondary series techniques. The benefit of prototype circuit is a low cost and simple design the prototype. The input voltage of prototype dc-dc converter is battery storage equal to 20-26 V. The experimental result of the proposed circuit show output voltage and output current range of 295-320 V and 3.16-4.75 A, respectively.

© 2013 The Authors. Published by Kasem Bundit University.

Selection and/or peer-review under responsibility of Faculty of Science and Technology, Kasem Bundit University, Bangkok.

Keywords: High Step-Up, Push-Pull converter, Parallel input, series output, High Step-up DC-DC converter

1. Introduction

In recent years, renewable energy systems are widely used to provide electric energy. The photovoltaic arrays, fuel cells and battery storage source are low-voltage supply, must be front-end circuit to boost low voltage to high voltage for inverter connected to ac voltage application. The high power dc-dc converter is a high voltage amplifier circuit used in distributed generation, electric vehicle, uninterruptible (UPS) and aerator water treatment application, which is the conversion of a low voltage battery storage to a high voltage, especially battery storage source must have a high step-up dc-dc converter to amplify a low dc voltage.

The aerator water treatment system is conduction of the oxygen into the water. His Majesty the King of Thailand research and development of the Chaipattana aerator uses to solve the water pollution problem. The Chaipattana aerator model RX-2 was granted a patent under His Majesty's name on 2 July 1993 [1]. The aerator

* Corresponding author. *E-mail address:* tony_tct@yahoo.com

water treatment system consists of the battery supply, dc-dc converter, 3-phase inverter drive, ac line and aerator, especially in the dc-dc converter, which is used to convert low battery voltage to high voltage for 3-phase inverter driver aerator.

The well-known conventional push-pull dc-dc converter circuit technique has been successfully employed to convert from low input voltage to high output voltage applications [2-4]. According to [5-6], the parallel-input/series-output technique used in designed the high power push pull dc-dc converter. This paper proposed design and implementation of high power step-up push-pull converter for 3-phase inverter drive aerator water treatment application. The principle of conventional push-pull dc-dc converter will be presented in Section II. Section III proposes the design of a high power step-up push-pull dc-dc converter with parallel input and series output of the transformer. The proposed control strategy of the converter will be presented in Section IV. An experimental results are presented in Section V. Section VI describes conclusions.

2. Conventional Push-Pull DC-DC Converter Circuitry

The conventional of push-pull dc-dc converter is shown in Fig. 1, which consists of mosfet switches ($M_{1a,b}$), transformer (TR), diode ($D_{1,4}$), output inductor (L_O) and capacitor (C_{OUT}). Fig. 2 shows the waveforms of the conventional push-pull dc-dc converter operation, which is operating in continuous conduction mode. As seen, the operation of the dc-dc converter circuit can be explained as follows. When gate voltage V_{G1a} is high level (V_{G1b} is low level), M_{1a} switches on (M_{1b} switches off), the input current flows through a primary of the transformer TR and the magnetic field in TR . The secondary voltage of transformer built up by expanding magnetic field. As a result, diode $D_{1,4}$ is forward biased and $D_{2,3}$ reverse biased. At the output stage, the output current flows through L_O and $D_{1,4}$ and charges the output capacitor C_{OUT} . When gate voltage V_{G1a} is low level (V_{G1b} is high level), which is operation after a dead time period, mosfet switches M_{1a} turns off (M_{1b} switches off), the input current is passed through a primary transformer TR and a voltage across secondary inverting. For the output converter, the output current is passed through $D_{2,3}$ and L_O , the output capacitor C_{OUT} charger.

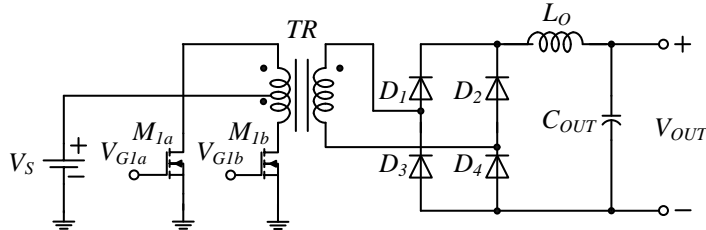

Fig. 1. Conventional push-pull converter circuit

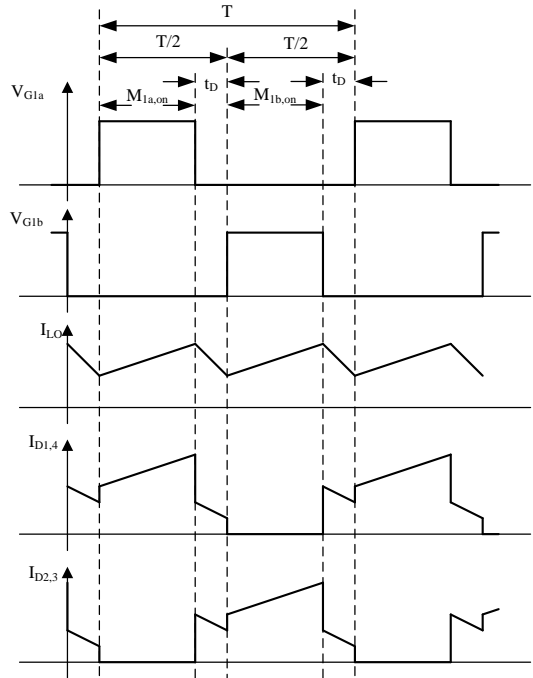

Fig. 2. Waveforms of the proposed converter operation

3. High power step-up push-pull converter design

The proposed high power step-up push-pull dc-dc converter is shown in Fig. 3. As seen, the proposed high power step-up push-pull dc-dc converter consists of the four push-pull dc-dc converter circuits connected in parallel at the input and series at the output. The input circuit of dc-dc converter consists of mosfet switches $M_{1a,1b}$, $R_{G1a,b}$ and R_{S1} while $M_{2a,2b}$ - $M_{4a,4b}$, $R_{G2a,b}$ - $R_{G4a,b}$, R_{S2} - R_{S4} and TR_{2-4} consist to be the second, third and fourth circuits. The output circuit consists of Diode $D_{1,4}$, resistor divider $R_{O1,2}$, Inductor and capacitor, while the transformer TR_{1-4} is the coupling between the input stage and the output stage. The input of high power dc-dc converter is applied to the battery storage and input capacitor.

The operation of the proposed dc-dc converter circuit can be explained as follows. When the switches $M_{1a} - M_{4a}$ tune on ($M_{1b} - M_{4b}$ tune off), the current of battery flow through $M_{1a} - M_{4a}$, into all of transformer, thus allowing the induced voltage in the secondary and the output current flow through diode $D_{1,4}$ and inductor. Since the output of all transformer is connected as series output, the output voltage is larger than the input voltage. When, $M_{1a} - M_{4a}$ tune off ($M_{1b} - M_{4b}$ tune on), the output current is passed through $D_{2,3}$ and L_O . As a result of this action, the output voltage is greater than the input voltage.

3.1 High power step-up push-pull converter design

In the design of the main power stage, the electrical specifications are $V_S = 20-26$ V, $V_{OUT} = 310$ V, $I_{OUT} = 3$ A and $f_s = 50$ kHz. The duty cycle (D) is determined from a switching frequency of 50 kHz and mosfet switches on time (t_{on}) = 10 μ s. According to [7], the maximum duty cycle (D_{max}) as

$$D_{max} = 0.9 \frac{t_{on}}{T} \tag{1}$$

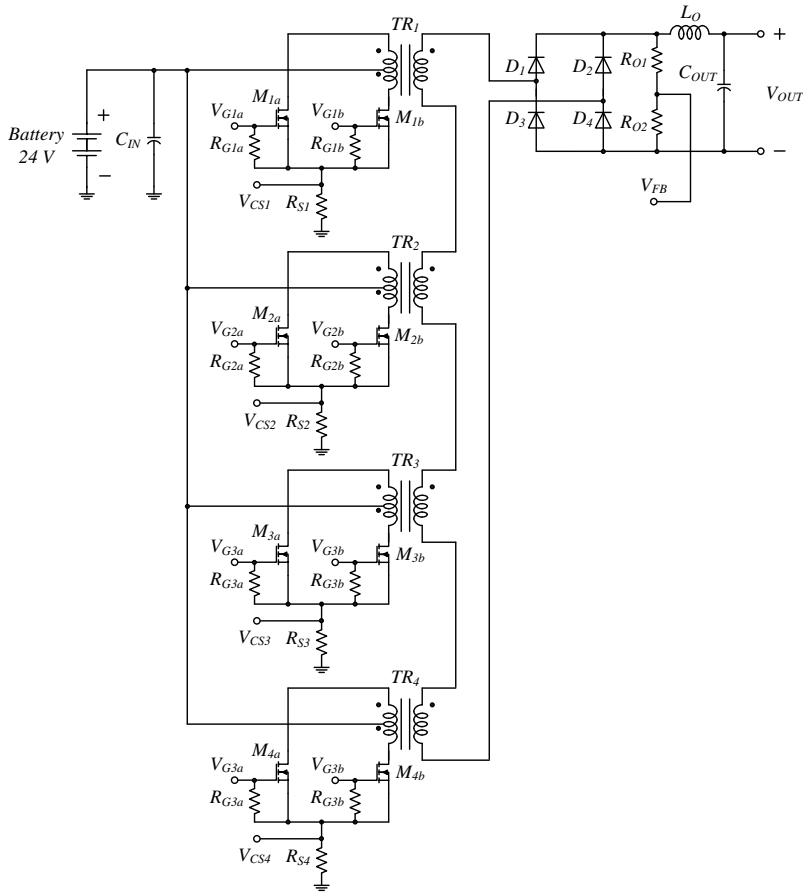

Fig. 3. The proposed high step-up push-pull converter topology

Thus, the maximum duty cycle (D_{max}) is

$$D_{max} = 0.45 \quad (2)$$

The maximum output power $P_{OUT} = 315 \text{ V} \times 6 \text{ A} = 1,890 \text{ W}$, thus maximum input power $P_{IN,max}$ is

$$P_{IN} = \frac{P_{OUT}}{0.9} = \frac{1,890\text{W}}{0.9} = 2.1\text{kW} \quad (3)$$

Therefore, the input current value is

$$I_{IN} = \frac{P_{IN}}{V_{IN,min}} = \frac{2.1\text{kW}}{20\text{V}} = 105\text{A} \quad (4)$$

where $V_{in,min}$ is the minimum input voltage, P_{OUT} is the output power. As the most of the input current, the parallel-input series-output techniques [xx] used in design. The high power dc-dc converter circuits to separated to four circuits, which using parallel at the input and series at the output is shown in Fig. 2.

3.2 Transformer design

Transformer ($TR_{1.4}$) is to convert the electrical voltage form a low voltage input to high voltage output signal with using the turn ratio technique. The turn ratio of switching transformer as

$$n = \frac{N_2}{N_1} = \frac{V_{OUT}}{2V_{IN,min}D_{max}} \quad (5)$$

where N_1 and N_2 are turn ratio of primary transformer and secondary transformer, respectively. Therefore, the turn ratio is

$$n = 17.5 \quad (6)$$

3.3 Output capacitor and inductor design

In output capacitor design, the minimum output current value is equal to $\Delta I / 2$, thus $I_{OUT,min} = 0.45$ A. The output voltage ripple is 1% of the output voltage. Therefore, $\Delta V_{OUT} = 3.15$ V. According to the current capacitor $i_C = I_{OUT,max} = 6$ A and the voltage capacitor ripple $dV_C = \Delta V_{OUT} = \Delta V_C = 3.15$ V, The output capacitor as

$$C = \frac{i_C \Delta t}{\Delta V_C} \quad (7)$$

Thus allowing the output capacitor is

$$C_{min} \geq 6.76 \mu F \quad (8)$$

The capacitor C_{OUT} is chosen equal to $220 \mu F$.

For output inductor, the output current ripple (ΔI_O) value is 0.9 A, also the minimum Output inductor is given by

$$L_{min} \geq \left(\frac{N_2}{N_1} V_{IN} - V_{OUT} \right) \frac{t_{on,max}}{\Delta I} \quad (9)$$

Therefore, the minimum output inductor value is

$$L_{min} \geq 1.167 mH \quad (10)$$

The inductor L_O is chosen using $1.5 mH$.

4. The proposed converter control circuitry

Fig. 4 shows the control of high power step up push-pull converter circuit. As seen, the PWM signal is generated by IC SG3525, which happened at output A and output B. The PWM signal is passed through transistor gate driver $Q_{1,2}$ ($Q_{3,4}$) and $R_{G1,3,5,7}$ ($R_{G2,4,6,8}$), transistor Q_1 and Q_2 (Q_3 and Q_4) is connected in the voltage follower configuration, the output PWM control circuit is connected to mosfet $M_{1a,1b} - M_{4a,4b}$. From Fig. 3, one can see that the output of the dc-dc converter circuit is connected to resistor voltage divider $R_{O1,2}$ in order to feed back the voltage divider to PWM control circuit. The voltage feedback (V_{FB}) is divided of the output voltage fed back voltage to PWM control at V_{FB} node in order to control a duty cycle of PWM signal, which is controlled the output voltage of high step-up push-pull dc-dc converter. In order to limit the input current, the op-amp LM 393 is used for sensing the input current flow through R_{S1-4} for protected to mosfet switches.

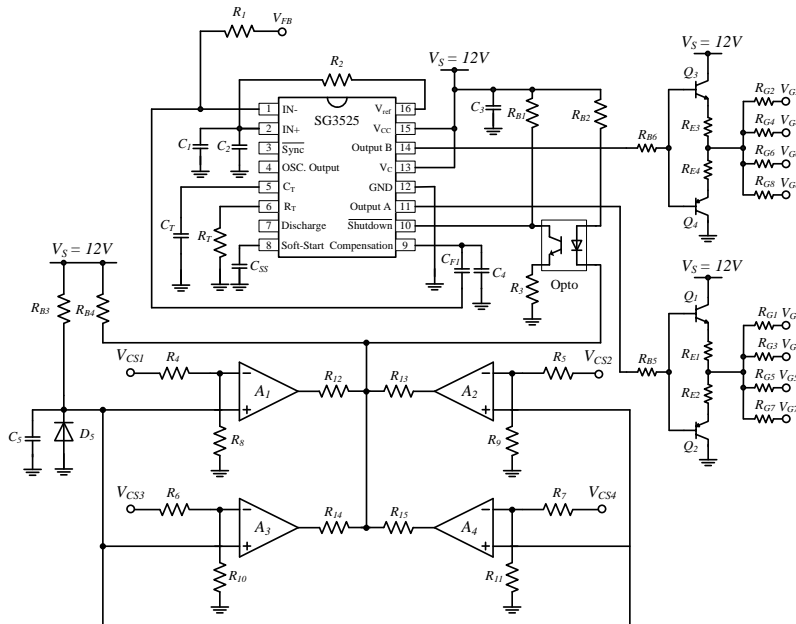

Fig. 4. Control high power step-up push-pull dc-dc converter scheme

5. Experimental Results

In order to verify the high power step-up push-pull dc-dc converter circuit performance, a dc-dc converter circuit is used to converter the voltage form 20 – 26 V to 310 V. The specifications of the high power converter are given as follows; 1) The battery voltage: $V_S = 20-26$ V, 2) The output voltage: $V_{OUT} = 310$ V, 3) The output current: $I_{OUT} = 3$ A, 4) The output power: $P_{OUT} = 1.5$ kW, 5) Switching frequency: $f_s = 50$ kHz, and 6) Mosfet switches $M_{1a,b} - M_{4a,b}$: IRFP2907.

Table 1 shows the components used in the proposed push-pull dc-dc converter prototype. Fig. 5(a) – (d) illustrated the experimental waveform of the gate voltage signal $V_{G1a-1b} - V_{G4a-4b}$ and the drain voltage signal $V_{D1} - V_D$. As seen, the results shows gate drive voltage is 12 V, drain voltage is 20 V and switch frequency is 50 kHz. In addition, the gate voltage $V_{G1a} - V_{G4a}$ driver mosfet switch, $M_{1a} - M_{4a}$ is turned on as the gate voltage $V_{G1b} - V_{G4b}$ is zero voltage, $M_{1b} - M_{4b}$ is turned off.

Fig. 6(a) illustrates the experimental of the High power step up push-pull converter with connected to the lamp load. Fig. 6(b) shows the experimental of the prototype with connected to the 3 phase inverter drive the aerator water treatment system.

Table 2 shows the experimental result of a high power step-up push-pull dc-dc converter, which is connected to the lamps, As seen, the results shows the input power is 211.2 – 1,560 W and the output power is 154.8 –

957.7 W. The experimental result of the push-pull converter circuits, which connected to the inverter drive the Chaipattana aerator, the output voltage and the output current range of 295-320 V and 3.16-4.75 A, respectively.

Table 1. The proposed converter components

Element	Description	Element	Description	Element	Description
M_{1a-4a}, M_{1b-4b}	IRFP2907	C_F	47nF	R_{G1a-4a}, R_{G1b-4b}	20k Ω
$Q_{1,3}$	BD139	C_{SS}	10 μ F	R_{S1-4}	0.01 Ω
$Q_{2,4}$	BD140	C_T	4.7 μ F	R_T	2.5k Ω
D_{1-4}	MUR1560	C_{IN}	18,800 μ F 50V	R_1	1.5k Ω
D_5	1N4148	C_{OUT}	220 μ F 470V	R_2, R_{4-7}	330 Ω
Op-amp	LM393	R_{B1-3}, R_3	1k Ω	R_{8-11}	2k Ω
Optocouple	PC817	R_{B4}	5k Ω	R_{12-15}	100 Ω
C_1	1 μ F	$R_{B5,6}, R_{G1-8}$	10 Ω	TR Core	ETD44
$C_{2,3,5,6}$	0.1 μ F	R_{E1-4}	6.8 Ω	L_O	500uH
C_4	10nF				

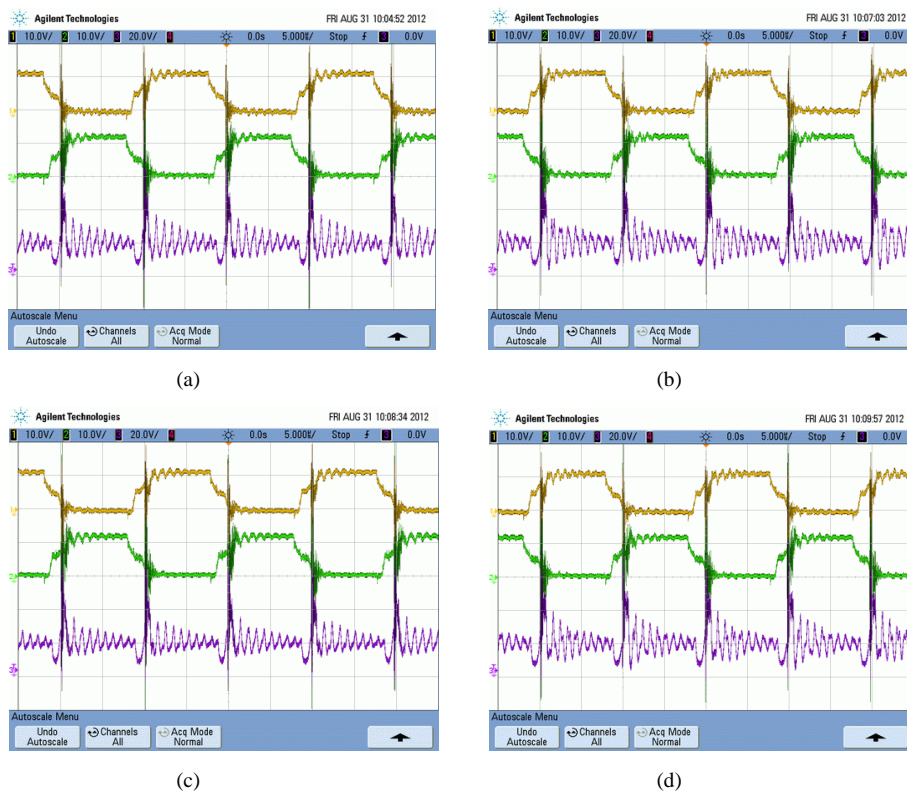

Fig. 5. The gate voltage and drain voltage signal, (a) V_{G1a1b} , and V_{D1} , (b) V_{G2a2b} , and V_{D2} (c) V_{G3a3b} , and V_{D3} , and (d) V_{G4a4b} and V_{D4}

Table 2. The experimental result of proposed circuits

$R_{Lamp} (\Omega)$	$V_{IN} (V)$	$I_{IN} (A)$	$P_{IN} (W)$	$V_{OUT} (V)$	$I_{OUT} (A)$	$P_{OUT} (W)$
6.8	24.00	65.0	1,560	307.0	3.1	957.7
9.2	24.00	36.0	864	315.0	2.1	661.5
11.3	24.00	35.0	840	314.0	2.1	659.4
12.3	24.00	25.0	600	312.4	1.6	499.84
14.3	24.00	25.0	600	312.2	1.6	499.52
36.7	24.00	8.8	211.2	309.6	0.5	154.8



(a)



(b)

Fig. 6. The experimental of the prototype (a) connected to lamp load, (b) connected to 3 phase inverter

6. Conclusion

This paper presented the design and implementation of a high power step-up push-pull converter circuits for 3-phase inverter drive aerator water treatment application. The push-pull dc-dc converter was controlled by IC SG3525 to control the operation of the mosfet switch, the switching frequency equal to 50 kHz. The proposed converter circuit used transformer is 4 units, which is implemented by 4 primary parallels and 4 secondary series techniques. The benefits of prototype circuit are a low cost and simple design the prototype. Finally, the input voltage of prototype dc-dc converter is battery storage range of 20-26 V. The experimental result of the push-pull converter circuits, which connected to the inverter drive the Chaipattana aerator speed range from 3 to 5 rpm, the output voltage range of 295-320 V and the output current range of 3.16-4.75 A.

Acknowledgements

I would like to thank the National Research Council of Thailand for grant fund under the Navamin Research for this research.

References

- [1] Aerator Chaipattana model RX-2, The Chaipattana Foundation : <http://www.chaipat.or.th>
- [2] W. C. P. de Aragao Filho and I. Barbi, "A Comparison between two current-fed push pull dc-dc converter-analysis, design and experimentation," IEEE 18th International Telecommunications Energy Conference (INTELEC 1996). 6-10, October 1996, p. 313-320
- [3] J. Ying, Q. Zhu, H. Lin, and Z. Wu, "A Zero-Voltage-switching (ZVS) push-pull dc/dc converter for UPS," The fifth International Conference on Power Electronics Drive Systems (PEDS 2003). 17-20, November 2003, p. 1495-1499.
- [4] J.-I. Kang, Ch.-W. Roh, G.-W. Moon and M.-J. Youn, "Phase-shifted parallel-input/series-output dual converter for high-power high-output voltage application," International Journal of Electronics. Vol. 89, no. 8, 2002, p. 603-624.
- [5] C.-L. Chu, and C.-H. Li, "Analysis and design of a current-fed zero-voltage-switching and -current-switching CL-resonant push-pull dc-dc converter," IET Power Electronic. Vol. 2, Iss. 4, 2009, p. 456-465.
- [6] J. Wang, J. Li, and W. Zhang, "Interleaved push-pull converter with very low input and high output," 2nd International Conference on Power Electronics and Intelligence Transportation System (PEITS 2009). 19-20, December 2009, p. 247-249.
- [7] AN2794 Application note, "1kW dual stage DC-AC converter based on the STP160N75F3," STMicroelectronics., February 2009, p. 7-18.